

INSTALLATION KIT

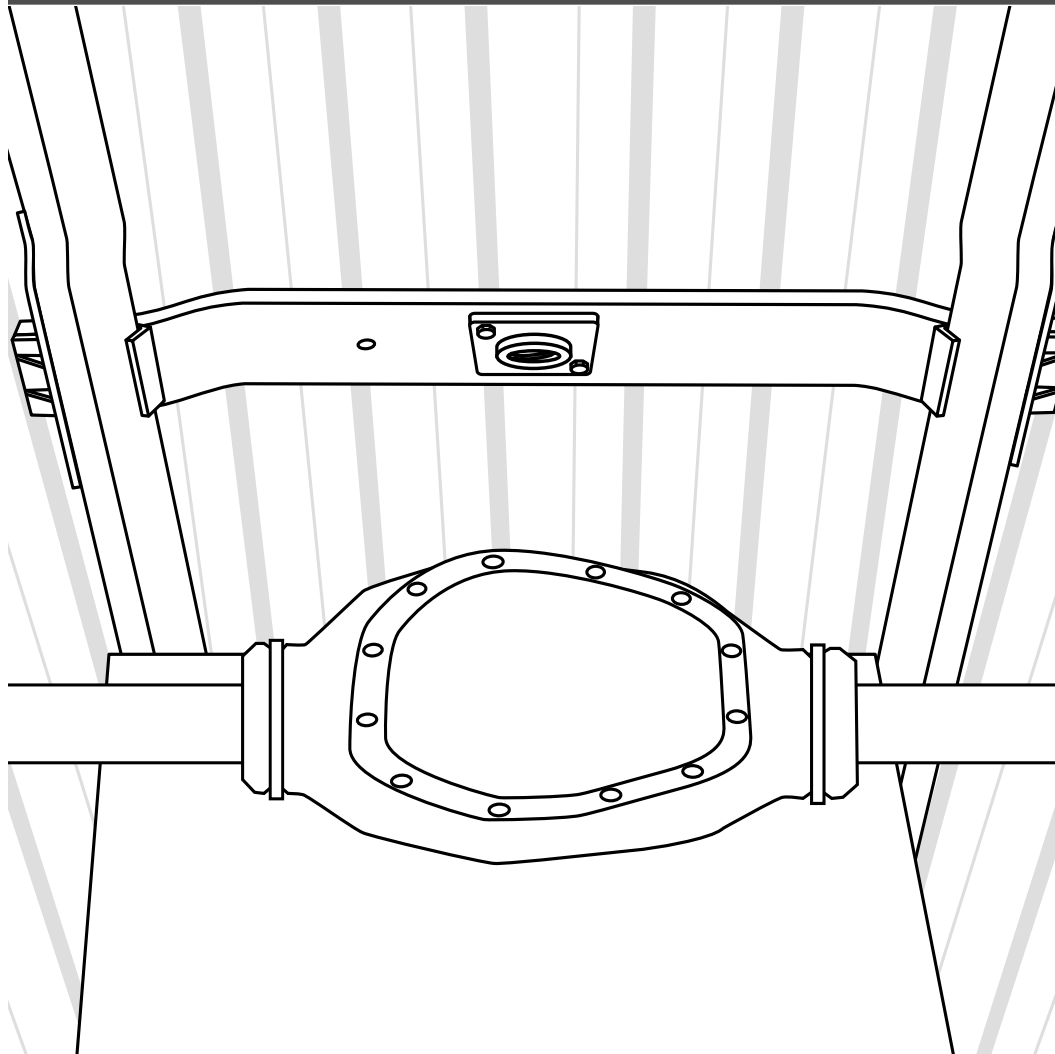

Main plate installation instructions for CHEVROLET®/GMC®.
Heavy Duty Frame 2500 / 3500
GMC Silverado / Sierra Short Bed / Dually 2001-2006
And all 3500 Long Bed Heavy Duty 2005/2006 Models

INTRODUCTION

We have been family owned and operated since 1976. Starting as a one-man custom fabrication shop, we developed into a nationally recognized company with cutting-edge design and technology in the towing industry. Colibert has single handedly changed the towing industry with new concepts that have given the consumer a variety of choices for their towing needs.

Colibert created the market for this new concept in towing and is proud of the fact that we continue to develop new ideas for towing.

All of our products are designed with the installer and consumer in mind, keeping things safe, simple and easy for all to use.

Mission Statement:

Provide quality products for the towing industry with integrity and excellent customer service to our customers and to the end user.

Note to Dealer/Installer:

Provide this manual to the consumer. Demonstrate how to load and unload the hitch as well as placement and removal of the hitch.



Parts List:

1. Main Plate (1)
2. Mounting Brackets - driver's side (a) and passenger side (b)
3. Nut Plate (1)
4. Plastic Plug (1)
5. Plug Wrench (1)
6. Shim Plates (4)
7. Bolt Back
7/8" x 1 1/2" Bolt (2)
7/8" x 2" Bolt (2)

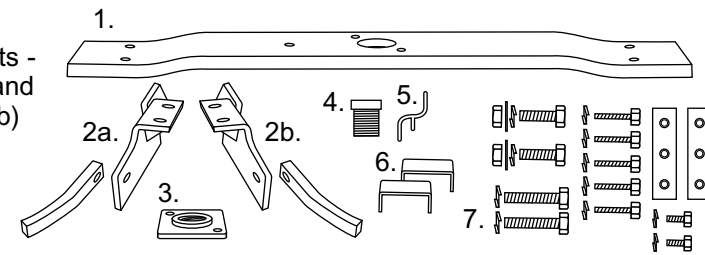

- | | |
|------------------------|------------------------|
| 7/8" Lock Washers (4) | 5/8" Lock Washers (4) |
| 7/8" Nuts (2) | Bar Nuts (2) |
| 7/8" Flat Washers (2) | 1/2" x 1 3/8" Bolt (2) |
| 5/8" x 1 1/2" Bolt (4) | 1/2" Lock Washers (2) |

Guidelines for Matching Truck and Trailer:

1. Trailer and all of its contents together must not exceed truck, hitch and/or trailer tow rating.
2. Towing vehicle must have a manufacturer's rated towing capacity equal to or greater than the gross trailer weight.
Gross Trailer Weight = Trailer + Cargo + Water in tanks.
3. Gross Trailer Weight must not exceed 30,000 pounds. (5,000 lbs. vertical load)
4. Long bed trucks are recommended for towing fifth wheel trailers due to turning radius. NOTE: If Towing with a short bed the distance from the back of the cab to the center of hitch locking jaws should be 4" greater than from the center of the king pin to the outer edge of the trailer. The addition of an extended king pin box may allow for a shorter turning radius.
5. The height of the hitch and king pin box needs to be adjusted so that the trailer tows close to level, allowing approximately 6" of clearance between the top of the truck bed and the overhang of trailer.

Call toll-free or visit us online for the dealer nearest you.
1-888-CE-HITCH www.colibert.com

INSTALLATION

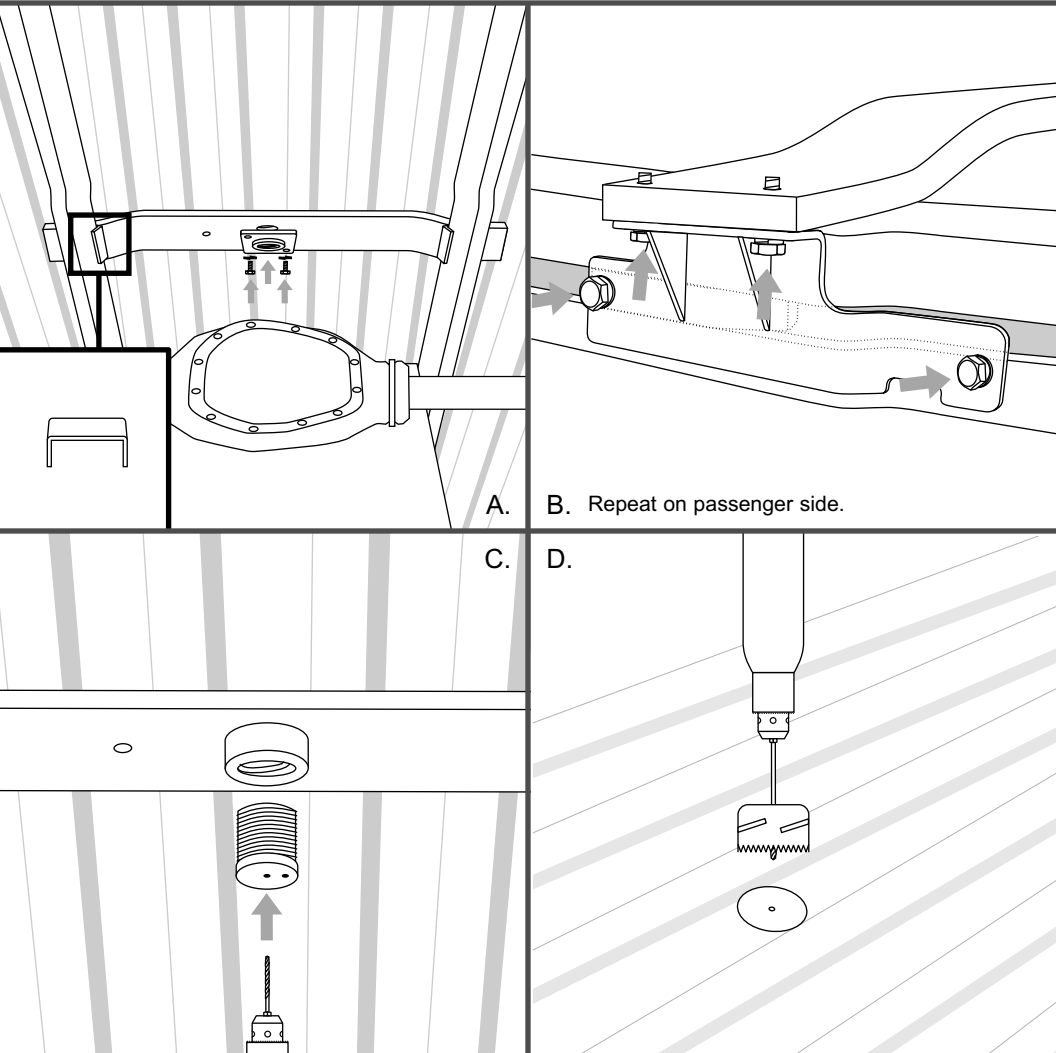

Installing the Main Plate*:

1. Remove spare tire to allow easier access to work area.
2. Place shims onto frame forward of cross member. This will level the frame area for the main plate. (Fig A.)
3. Slide main plate into wheel well opening placing plate on top of frame. The recessed hole faces down. Slide main plate above exhaust heat shield and onto opposite frame rail. (3/4" hole must be on drivers side.) (Fig A.)
4. Install side mounting brackets to bottom side of main plate using 5/8" bolts. (These mount on the outside of the frame.) **DO NOT TIGHTEN AT THIS TIME.** (Fig A.)
5. Attach side mounting brackets to side of frame using 7/8" x 2" bolt in rear hole of bracket on inside of frame, use flat washer, lock washer and nut. In forward hole use 7/8" x 1 1/2" bolt from outside, drilled and tapped bar nut on the inside of frame. Repeat on other side of truck. (Fig B.)
Note: forward hole must be drilled on dually and long bed.
6. Torque 5/8" bolts to 200 ft. lb. 7/8" bolts to 350 ft. lb.
7. Install nut to recessed underside of main plate using 1/2" bolts. Torque to 75 ft. lb.
8. From underside of bed install plastic bed plug. Using 1/4" drill bit insert bit in center hole and drill up through bed. Remove plastic plug. (Fig C.)
9. From inside of bed use 3" hole saw with 1/4" pilot bit to open bed for ball plate access. (Fig D.)
10. Reinstall spare tire.

*Your main plate assembly may vary depending on your vehicle. Because every truck is different, there may be slight differences in the main plate delivered with your hitch.

Note:

When not using hitch, install plastic plug into main plate from the truck bed to protect the threads and prolong the life of your hitch.

WARRANTY

Colibert Enterprises' Limited Lifetime Warranty

This Warranty applies solely to those items manufactured by Colibert Enterprises (Receivers, Gooseneck Products, Ball Mounts, Receiver Products, Hitches, Hitch Balls).

1. **Warranty and Warranty Period.** Colibert Enterprises warrants to the original Purchaser/Consumer of the products that Colibert Enterprises will provide, free of charge, the replacement of any products which are defective in material or workmanship (the "Warranty"). This Warranty applies only to the original Purchaser/Consumer of the products for as long as the original Purchaser/Consumer owns the vehicle on which the products were installed. Defective products returned to Colibert Enterprises become the property of Colibert Enterprises.
2. **Limitations on the Warranty.** The following limitations apply to the Warranty.
 - a. The Warranty applies only to products which are defective in material or workmanship and does not cover normal wear and tear. The Warranty does not cover service or labor charges which are incurred in removing or replacing any products.
 - b. The Warranty does not cover the finish placed on products by Colibert Enterprises. Accordingly, Colibert Enterprises will not replace, repair or re-finish any products if the finish of the product is worn in any manner.
 - c. The Warranty does not extend to products which are damaged or which fail as a result of the products being abused, neglected, or misused in any manner, or as a result of any accident, or which are misapplied, overloaded, improperly installed, or altered in any manner by anyone other than Colibert Enterprises.
3. **Obligation of Purchaser/Consumer.** To obtain the benefits of the Warranty, the Purchaser/Consumer must complete the following steps. a) The Purchaser/Consumer must present the defective product(s) together with the proof of purchase to any of Colibert Enterprises' dealers, distributors, or its factory. b) The Purchaser/Consumer must pay all handling, transportation, and shipping charges incurred for the return of the defective product(s) to Colibert Enterprises and for the delivery of the replacement products(s) by Colibert Enterprises to the Purchaser/Consumer.

4. **Obligations of Colibert Enterprises.** Subject to the terms and limitations set forth in this document, Colibert Enterprises will provide replacement product(s) to the original Purchaser/Consumer free of charge.

5. **Legal Rights and Limitation of Purchaser/Consumer.** THIS WARRANTY GIVES YOU SPECIFIC LEGAL RIGHTS AND YOU MAY ALSO HAVE OTHER RIGHTS WHICH VARY FROM STATE TO STATE. ANY IMPLIED WARRANTY OF MERCHANTABILITY OR FITNESS FOR A PARTICULAR PURPOSE ON ANY COLIBERT ENTERPRISES PRODUCT SHALL BE LIMITED TO ONE (1) YEAR FROM THE DATE OF PURCHASE AT RETAIL TO THE ORIGINAL PURCHASER. SOME STATES DO NOT ALLOW LIMITATIONS ON HOW LONG AN IMPLIED WARRANTY LASTS, SO THE ABOVE LIMITATIONS MAY NOT APPLY TO YOU.

COLIBERT ENTERPRISES SHALL NOT BE LIABLE OR ASSUME RESPONSIBILITY FOR THE LOSS OF THE USE OF ANY VEHICLE, LOSS OF TIME, RENTAL OF VEHICLES, LOSS OR DAMAGE TO PERSONAL PROPERTY, EXPENSES SUCH AS GASOLINE, TELEPHONE, LODGING, OR TOWING, OR ANY OTHER INCIDENTAL OR CONSEQUENTIAL DAMAGES INCURRED AS A RESULT OF THE USE OR OWNERSHIP OF ANY PRODUCTS. SOME STATES DO NOT ALLOW THE EXCLUSION OF A LIMITATION OF INCIDENTAL OR CONSEQUENTIAL DAMAGES, SO THE EXCLUSION OR LIMITATION SET FORTH MAY NOT APPLY TO YOU. REPLACEMENT OF THE PRODUCT IN THE MANNER PROVIDED ABOVE SHALL CONSTITUTE FULFILLMENT OF ALL LIABILITIES OF COLIBERT ENTERPRISES TO THE PURCHASER/CONSUMER WHETHER BASED ON CONTRACT OR OTHERWISE.

COLIBERT ENTERPRISES RESERVES THE RIGHT TO MAKE CHANGES IN DESIGN OR TO MAKE ADDITIONS OR IMPROVEMENTS WITHOUT BEING OBLIGATED TO INSTALL THE SAME UPON PRODUCTS COVERED BY THIS WARRANTY. THIS WARRANTY VALID ONLY IN THE UNITED STATES AND CANADA.

We are proud of our reputation with our customers based on our Quality and Customer Service.

HITCHING SOLUTIONS

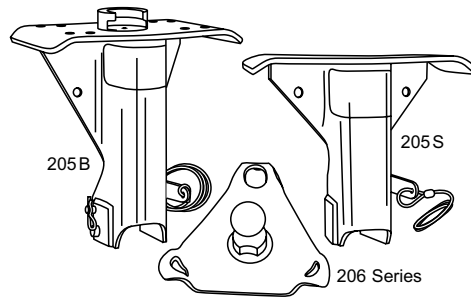

The Gooseneck fifth wheel hitch converter that gives you your truck bed back.

206 Series Hitch Assembly

Sold separately, will work with any gooseneck system and is the safest and most convenient "easy out" system in the market.

- Ball plate with 2 5/16" ball spins in/out.
- 30,000 lbs. rating (5,000 lbs. vertical load)
- Requires only one 3" hole in truck bed.
- Complete kit—nothing else to buy.

205B/S Fifth Wheel Gooseneck Adapters

Automatic latching couplers attach to any fifth wheel trailer.

- Drop down style coupler allows full range of motion for easy hookup and disconnect.
- Comes with remote release.
- Can be moved from one trailer to another.
- 30,000 lbs. rating (7,500 lbs. vertical load)

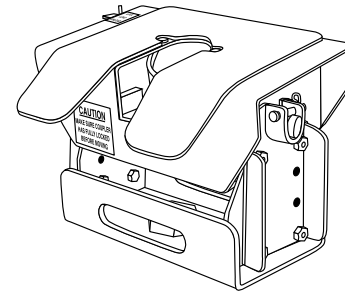

FREE RIDE—the fifth wheel hitch that's there when you need it, not when you don't.

Your truck bed is more than just a place for your fifth wheel hitch. That's why when you're not towing, the Free Ride can be removed completely and easily, leaving your bed flat and clear.

- Rated to 18,000 pounds. (3,500 lbs. vertical load)
- No towing hardware in your bed when you don't need it.
- Easy on/off design.
- No drilling into your truck frame.
- No need for a lockout device.
- Adjustable height & durable powder coated finish.
- Side-to-side pivot of 10 degrees.



FREE RIDE
HITCH TODAY, GONE TOMORROW.

Call toll-free or visit us online for the dealer nearest you.
1-888-CE-HITCH www.colibert.com